

UKC1 Contactor (50A-85A)

UKC1交流接触器

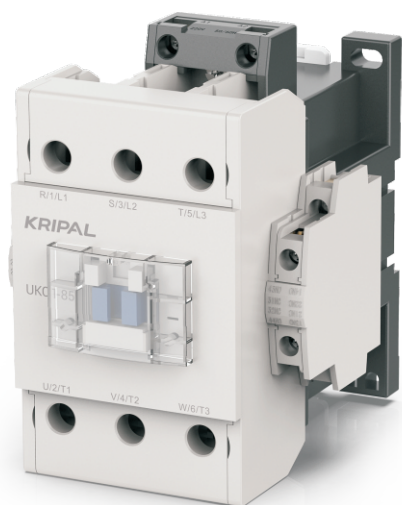

UKC1-85/3

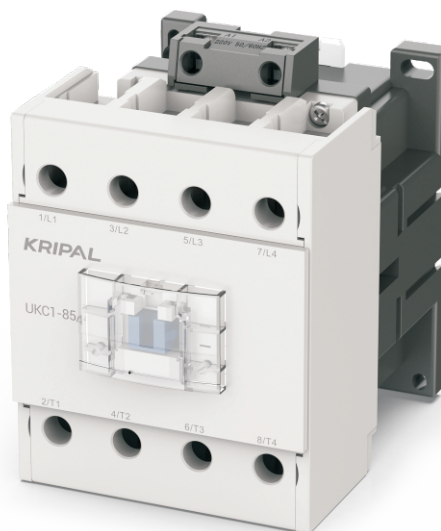

UKC1-85/4

特点 Characteristics

- 一个框架四个额定电流等级
 - 3极3对主触点, 4极4对主触点
 - 防触电安全罩设计
 - 导轨或螺钉安装
 - 可在顶部/侧面安装附件
 - 可与热过载继电器直接插接
- One frame with four rated current classes
 - 3 pairs of main contacts
 - Design of anti-electric shock cover
 - Installation of guide rail or screw
 - The accessory can be mounted on the top or at side.
 - Be connected with the thermal overload relay directly

接触器 (交流线圈) Contactors(AC coil)

型号 Type	额定电流 Rated current	AC3(IEC60947)				AC1 Ith	辅助触点(标准) Aux. Contacts
		220~240V	380~440V	500~550V	690V		
UKC1-50/3	50A	15KW 55A	22KW 50A	30KW 43A	30KW 28A	80A	1NO+1NC
UKC1-50K							选择 Select
UKC1-50/4							选择 Select
UKC1-65/3	65A	18.5KW 65A	30KW 65A	33KW 60A	33KW 35A	100A	1NO+1NC
UKC1-65K							选择 Select
UKC1-65/4							选择 Select
UKC1-75/3	75A	22KW 75A	37KW 75A	37KW 65A	37KW 42A	110A	1NO+1NC
UKC1-75K							选择 Select
UKC1-75/4							选择 Select
UKC1-85/3	85A	25KW 85A	45KW 85A	45KW 75A	45KW 45A	135A	1NO+1NC
UKC1-85K							选择 Select
UKC1-85/4							选择 Select

UKC1 Contactor (50A-85A)

UKC1交流接触器

线圈电压交流 Coil voltage, AC50/60Hz

50Hz: 24, 42, 48, 100, 110, 220, 240, 380, 400, 415, 440, 500, 550V

60Hz: 24, 48, 110, 120, 208, 220, 240, 277, 380, 440, 480, 600V

接触器 (直流线圈)Contactors(DC coil)

型号 Type	额定电流 Rated current	AC3(IEC60947)				AC1 Ith	辅助触点(标准) Aux. Contacts
		220~240V	380~440V	500~550V	690V		
UKD1-50/3	50A	15KW 55A	22KW 50A	30KW 43A	30KW 28A	80A	1NO+1NC
UKD1-50K							选择 Select
UKD1-50/4							
UKD1-65/3	65A	18.5KW 65A	30KW 65A	33KW 60A	33KW 35A	100A	1NO+1NC
UKD1-65K							选择 Select
UKD1-65/4							
UKD1-75/3	75A	22KW 75A	37KW 75A	37KW 65A	37KW 42A	110A	1NO+1NC
UKD1-75K							选择 Select
UKD1-75/4							
UKD1-85/3	85A	25KW 85A	45KW 85A	45KW 75A	45KW 45A	135A	1NO+1NC
UKD1-85K							选择 Select
UKD1-85/4							

线圈电压直流 Coil voltage, DC

12, 20, 24, 48, 60, 80, 100, 110, 125, 200, 220, 250V

安装与接线 Installation and connection

安装 Installation	35mm导轨或螺钉(M4)固定 Fixed by 35mm guide rail or screw (M4)		
接线 Connection	主触点 Main contact	50A框架 Frame	螺钉(M6)压线式端子 Screw(M6) crimping terminal 线径 Wire dia:2~22mm ²
		65/75/85A 框架 Frame	螺钉压线式端子 Screw crimping terminal 线径 Wire dia:2~38mm ²
		辅助触点/线圈 Auxiliary contact/coil	螺钉(M3.5)压线式端子 Screw(M3.5) crimping terminal

UKC1 Contactor (50A-85A)

UKC1交流接触器

可选附件 Optional accessory

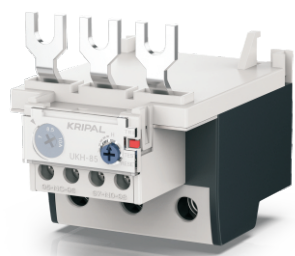
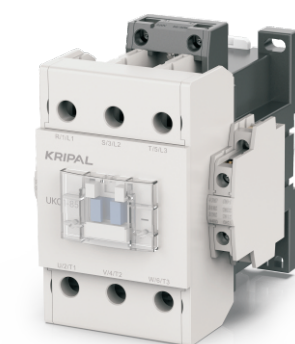

UKH-85 热（双金属片）式
UKH-85 Thermal (bimetal) type



AU-1 辅助触点单元,
2极侧装
AU-1 auxiliary contact unit
2-pole, side mounting



AU-2 辅助触点单元,
2极顶部安装
AU-2 auxiliary contact unit,
2-pole, top mounting



AU-4 辅助触点单元,
4极顶部安装
AU-4 auxiliary contact unit
4-pole, top mounting



AR-9 机械联锁单元
AR-9 Mechanical interlock unit



AS 浪涌抑制单元
AS Surge suppressing unit

Technical Specifications

技术参数

电气寿命曲线图(UKC1-9-85) The electrical life time(UKC1-9-85)

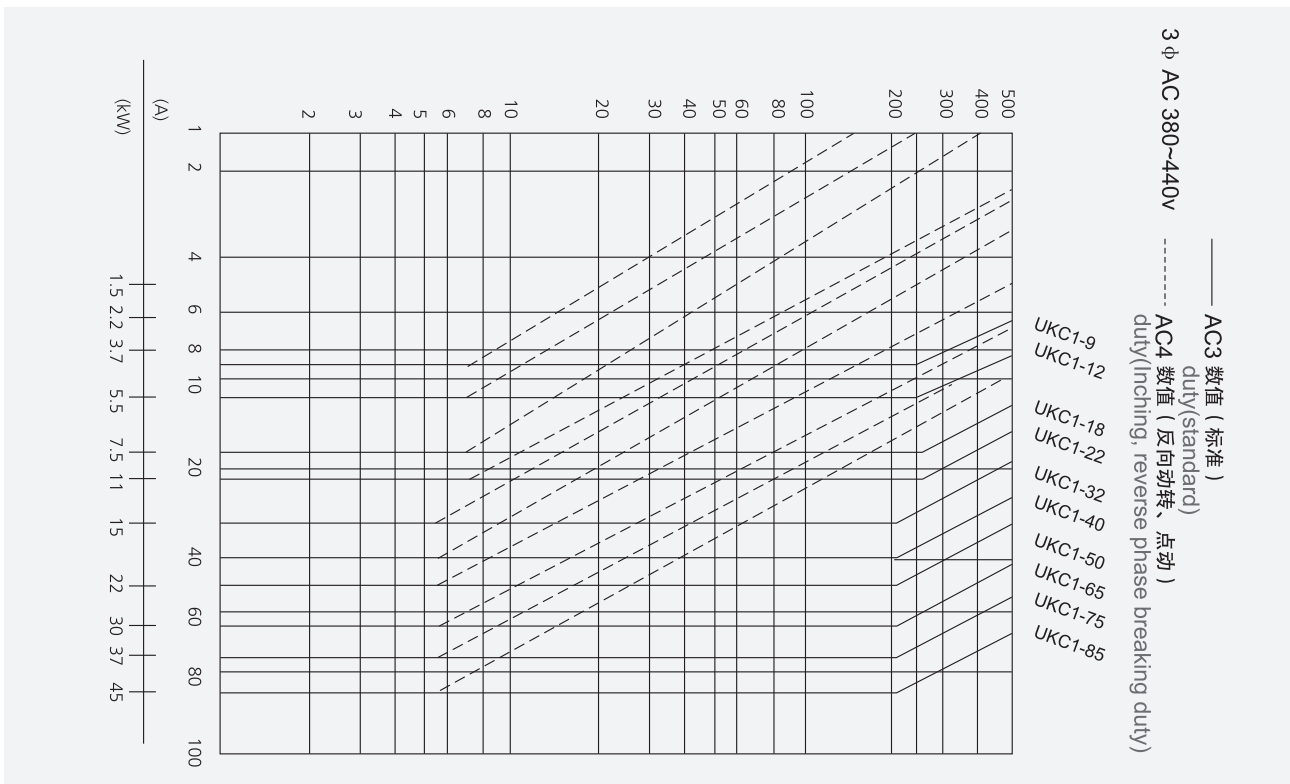
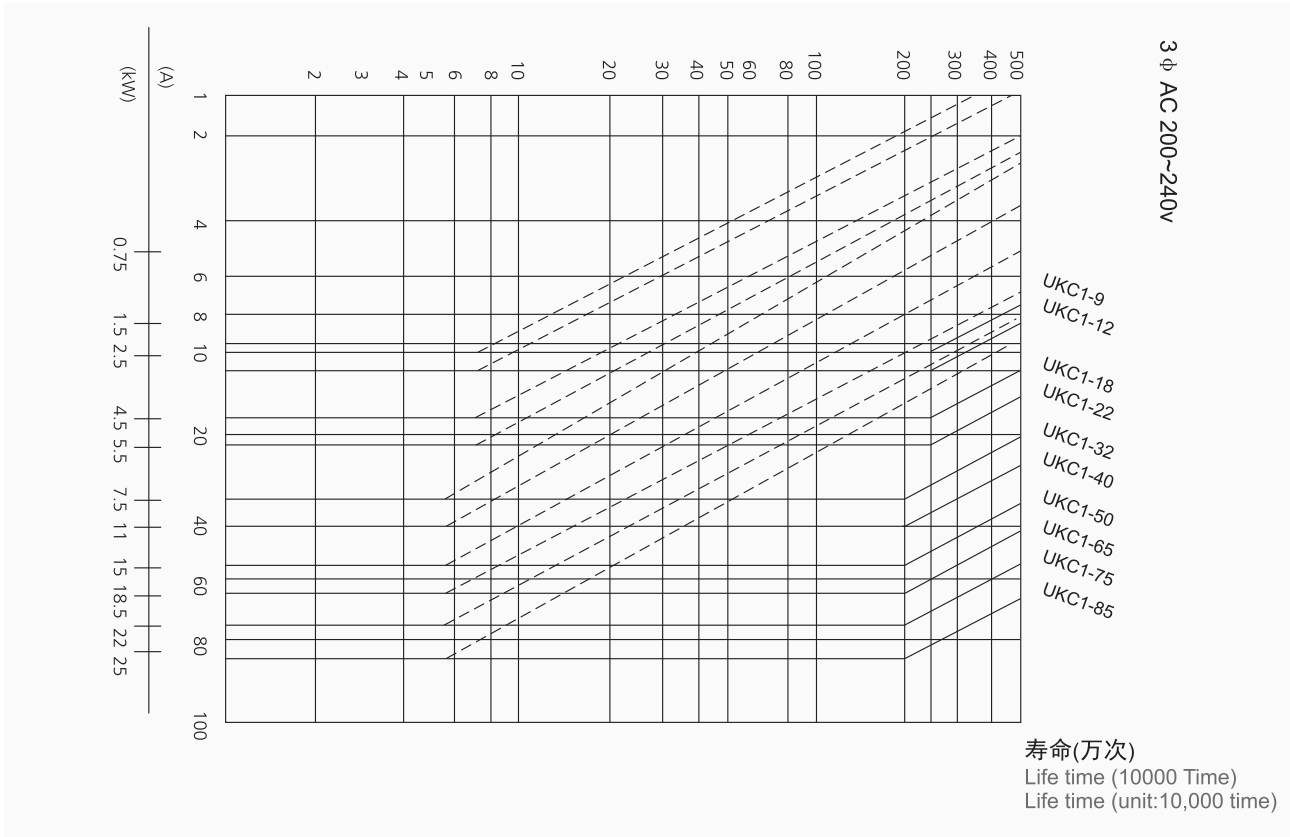

Technical Specifications

技术参数

额定容量 Rated capacity

型号 Model		额定 Rated																AC1类 负载 AC1 load (Ith)
接触器 Magnetic contactors	电机启动器 Magnetic switches	AC3类负载 AC3 load						AC2类负载 AC2 load						AC4类负载 AC4 load				
		200~220V		380~440V		500~550V		200~220V		380~440V		500~550V		200~220V		380~440V		
		KW	A	KW	A	KW	A	KW	A	KW	A	KW	A	KW	A	KW	A	
UKC1-9	UKC1-9+UKH-22	2.5	11	4	9	4	7	2.5	11	4	9	4	7	1.5	8	2.2	6	25
UKC1-12	UKC1-12+UKH-22	3.5	13	5.5	12	7.5	12	3.5	13	5.5	12	7.5	12	2.2	11	4	9	25
UKC1-18	UKC1-18+UKH-22	4.5	18	7.5	18	7.5	13	4.5	18	7.5	18	7.5	13	3.7	18	4	9	40
UKC1-22	UKC1-22+UKH-22	5.5	22	11	22	15	22	5.5	22	11	22	15	22	3.7	18	5.5	13	40
UKC1-32	UKC1-32+UKH-40	7.5	32	15	32	18.5	28	7.5	32	15	32	18.5	28	4.5	20	7.5	17	50
UKC1-40	UKC1-40+UKH-40	11	40	18.5	40	22	32	11	40	18.5	40	22	32	5.5	25	11	24	60
UKC1-50	UKC1-50+UKH-85	15	55	22	50	30	43	15	55	22	50	30	43	7.5	35	15	32	80
UKC1-65	UKC1-65+UKH-85	18.5	65	30	65	33	60	18.5	65	30	65	33	60	11	50	22	47	100
UKC1-75	UKC1-75+UKH-85	22	75	37	75	37	64	22	75	37	75	37	64	13	55	25	52	110
UKC1-85	UKC1-85+UKH-85	25	85	45	85	45	75	25	85	45	85	45	75	15	65	30	62	135
UKC1-100	UKC1-100+UKH-100	30	105	55	105	55	85	30	105	55	105	55	85	19	80	37	75	160
UKC1-125	UKC1-125+UKH-100	37	125	60	120	60	90	37	125	60	120	60	90	22	93	45	90	160
UKC1-150	UKC1-150+UKH-150	45	150	75	150	90	140	45	150	75	150	90	140	30	125	55	110	200
UKC1-180	UKC1-180+UKH-220	55	180	90	180	110	180	55	180	90	180	110	180	37	150	75	150	230
UKC1-220	UKC1-220+UKH-220	75	250	132	250	132	200	75	250	132	250	132	200	45	180	90	180	260
UKC1-330	UKC1-330+UKH-630	100	330	200	330	200	310	100	330	200	330	200	310	60	240	120	240	400
UKC1-400	UKC1-440+UKH-630	110	400	250	400	257	400	110	400	250	400	257	400	75	300	150	300	500
UKC1-500	UKC1-500+UKH-630	147	500	295	500	355	450	147	500	295	500	355	450	90	330	160	330	700
UKC1-630	UKC1-630+UKH-630	200	630	400	630	400	600	200	630	400	630	400	600	115	420	210	420	1000

辅助触点额定容量 Rated capacity of auxiliary contacts

型号 Model	额定电流 Rated current(A)								AC1 (Ith)
	AC15		DC13		AC12		DC12		
	120V	240V	480V	600V	125V	250V	440V	600V	A
UKC(D)1-6M~16M	4	2	1.0	0.8	2	1.0	0.4	0.2	16
UKC(D)1-9~22	6	3	1.5	1.2	3	1.5	0.55	0.27	16
UKC(D)1-32~85	6	3	1.5	1.2	3	1.5	0.55	0.27	16
UKC1-100~800	6	5	3	3	6	3	1.2	0.2	16

Technical Specifications

技术参数

辅助触点数 NO. of contact

型号 Model	标准 Standard	选择 Option
UKC(D)1-6M~16M	1 NO	1NO 1NC, 2NO 2NC
UKC(D)1-9~22	1 NO 1NC	4NO, 3NO 1NC, 2NO 2NC, 1NO 3NC
UKC(D)1-32~85	2 NO 2NC	4NO, 3NO 1NC, 2NO 2NC, 1NO 3NC
UKC1-100~220	2 NO 2NC	2NO 2NC
UKC1-330~800	-	4NO, 3NO 1NC, 2NO 2NC, 1NO 3NC

操作线圈额定值 Ratings of the operational coil

6~85A

型号 Type	交流线圈 AC coil		直流线圈 DC coil
	AC 50Hz	AC 60Hz	DC
UKC(D)1 6(/4)~85(/4)	24V	24V	12V
	42V	48V	24V
	48V	110V	48V
	100V	120V	100V
	110V	208V	110V
	220V	220V	125V
	240V	240V	200V
	380V	277V	220V
	400V	380V	250V
	415V	440V	-
440V	480V	-	
500V	600V	-	
550V	-	-	

100~800A

型号 Type	电压等级 Voltage grade	交直流线圈 AC/DC coil	
		AC 50Hz/60Hz	DC
UKC1-100(/4) 220(/4)	24V*	24V~25V	24V
	48V*	48V~50V	48V
	100~200V	100~240V	100~220V
	300V	265~247V	-
	400V	380~450V	-
UKC1-330<4> -800<4>	500V	440~575V	-
	100V	100~127V	100~110V
	200V	200~240V	200~220V
	300V	265~347V	-
	400V	380~450V	-
500V	440~575V	-	

线圈范围 Selections of coil

在UKC1-6~85接触器50Hz和60Hz要区分, UKC1-100~800接触器可选择单交流或交、直流通用线圈(直流低于220V)。In UKC1-6~85 contactors, 50Hz coil and 60Hz coil are separated. But in UKC1-100~800 contactors, the coils are AC/DC common use, (under DC 220V).

线圈电压范围 Ranges of the coil voltage

环境温度在40℃线圈电压和频率为额定值时, 线圈处于饱和状态。此时线圈上的电压为额定值的85~110%。When it is saturated after apply the rated voltage and rated frequency at 40℃, the coil operate at 85~110% of the rated voltage. 当线圈在可允许范围以外运行时, 其绝缘性能和机械性能可能会受害。When the coil is operated below or over the variable ranges it is apt to be deteriorated in electrical insulation and mechanical operation.

When the coil is operated below or over the variable ranges it is apt to be deteriorated in electrical insulation and mechanical operation.

交流操作线圈特点 Characteristics of the AC coil

AC 220V 50Hz

型号 Type	线圈损耗 Coil consumption[VA]		热损 Heat dissipation [W]	动作电压 Operational voltage[V]		线圈电流 Coil current[mA]	操作时间 Operational time(ms)	
	启动时 Inrush	吸合时 Sealed		吸合电压 Pick-up voltage	释放电压 Droup-out voltage		闭 Closing	开 Opening
UKC1-9(/4)~22(/4)	95	9	2	142~157(141~156)*	112~132(105~125)*	36(41)	10~17	6~9
UKC1-32(/4),40(/4)	95	9	2	151~166(150~165)*	117~137(110~130)*	36(41)	11~19	6~10
UKC1-50(/4)~85(/4)	220	17	5	146~161(145~160)*	107~127(100~120)*	68(77)	16~25	8~15
UKC1-100,125	298	12.3	4.4	77	48	56	30~34	63~67
UKC1-150	298	12.3	4.4	77	48	56	37~41	47~52
UKC1-180,200	380	11.6	4.7	77	48	53	45	45
UKC1-100(/4)~220(/4)	380	11.6	4.7	77	48	53	45	45

注) 1.以上是平均值 2.(*)内为50Hz时的数值 Note) 1.The aboves are average values. 2.(*)are the values for 50Hz)

Technical Specifications

技术参数

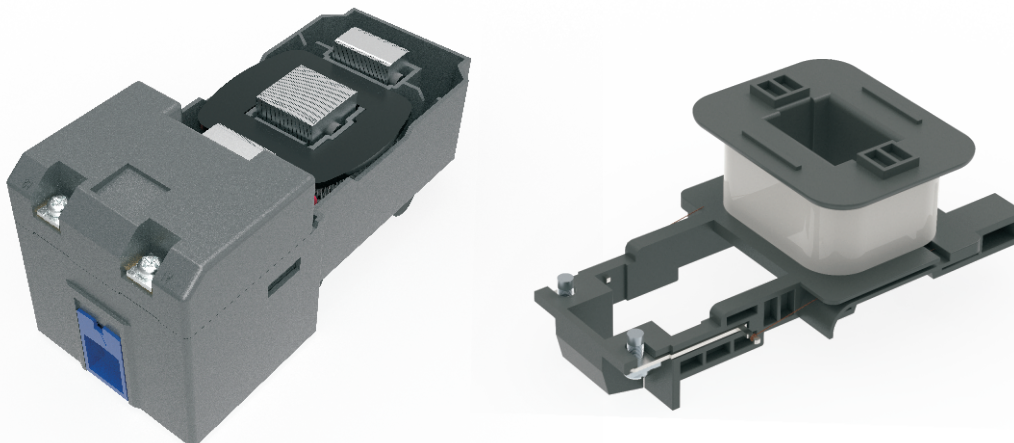

AC 110V, 50Hz

型号 Type	线圈损耗 Coil consumption[VA]		热损 Heat dissipation [W]	动作电压 Operational voltage[V]		线圈电流 Coil current[mA]	操作时间 Operational time(ms)	
	启动时 Inrush	吸合时 Pick-up		吸合电压 Pick-up voltage	释放电压 Droup-out voltage		闭 Closing	开 Opening
UKC1-9(/4)~22(/4)	95	8	2	74~84(75~85)	54~64(55~65)*	73(73)*	11~18	6~9
UKC1-32(/4)~40(/4)	95	8	2	75~84(75~85)	54~64(55~65)*	73(73)*	13~20	6~9
UKC1-50(/4)~85(/4)	220	17	5.5	67~77(68~78)	39~49(40~50)*	154(154)*	16~25	9~16
UKC1-100,125	162	9.8	3.1	77	48	89	46~50	49~53
UKC1-150	162	12.2	3	77	48	111	56~60	44~48
UKC1-180,200	220	9.1	3.4	77	48	83	60	41
UKC1-100(/4),220(/4)	220	9.1	3.4	77	48	83	60	41

注) 1.以上是平均值 2.(*)内为50Hz时的数值 Note) 1.The aboves are average values. 2.(*)are the values for 50Hz

直流操作线圈特点 Characteristics of the DC coil

直流电110伏基准 DC 110V dasis

型号 Type	线圈损耗(VA) Coil consumption		热损 Heat dissipation [W]	操作电压(V) Operational voltage		线圈电流(mA) Coil current	动作时间(ms) Operational time	
	启动时 Inrush	吸合时 Pick-up		吸合电压 Pick-up voltage	释放电压 Droup-out voltage		闭 Closing	开 Opening
UKD1-9(/4)~22(/4)	9	9	50	60~75	15~35	82	45~55	8~15
UKD1-32(/4),40(/4)	9	9	50	60~75	15~35	82	45~55	8~15
UKD1-50(/4)~85(/4)	220	5	-	65~80	15~35	46	20~30	13~20

注:1.以上是平均值。 Note:1. The aboves are average values

Technical Specifications

技术参数

电磁接触器保护性能 Performance of the magnetic contactors

型号 Type	额定电压(V) Rated voltage	额定电流(A) Rated current	短路分断电流(A) Short breaking current		额定操作频率 Operating cycles per hour(AC3 duty)	寿命(次:10,000) Life time(unit:10,000 time)		额定使用类别 Performance indicate
			接通 Short circuit	分断 Breaking		机械 Mechanical	电气 Electrical	
UKC1-9	220	11	132	110	1800	2500	250	AC3.1.0-0
	440	9	108	90				
UKC1-12	220	13	156	130	1800	2500	250	AC3.1.0-0
	440	12	144	120				
UKC1-18	220	18	216	180	1800	2500	250	AC3.1.0-0
	440	18	216	180				
UKC1-22	220	22	264	220	1800	2500	250	AC3.1.0-0
	440	22	264	220				
UKC1-32	220	32	385	320	1800	1500	200	AC3.1.0-0
	440	32	385	320				
UKC1-40	220	40	480	400	1800	1500	200	AC3.1.0-0
	440	40	480	400				
UKC1-50	220	55	660	550	1200	1000	200	AC3.1.0-0
	440	50	600	500				
UKC1-65	220	65	780	650	1200	1000	200	AC3.1.0-0
	440	65	780	650				
UKC1-75	220	75	900	750	1200	1000	200	AC3.1.0-0
	440	75	900	750				
UKC1-85	220	80	960	800	1200	1000	200	AC3.1.0-0
	440	80	960	800				
UKC1-100	220	105	1050	1050	1200	500	100	AC3.1.0-0
	440	105	1050	1050				
UKC1-125	220	125	1250	1250	1200	500	100	AC3.1.0-0
	440	120	1200	1200				
UKC1-150	220	150	1500	1500	1200	500	100	AC3.1.0-0
	440	150	1500	1500				
UKC1-180	220	180	1800	1800	1200	500	100	AC3.1.0-0
	440	180	1800	1800				
UKC1-220	220	250	2200	2200	1200	500	100	AC3.1.0-0
	440	250	2200	2200				
UKC1-330	220	330	3300	3300	600	300	50	AC3.1.0-0
	440	330	3300	3300				
UKC1-400	220	400	4000	4000	600	100	30	AC3.1.1-1
	440	400	4000	4000				
UKC1-500	220	500	5000	5000	600	100	30	AC3.1.1-1
	440	500	5000	5000				
UKC1-630	220	630	6300	6300	600	100	20	AC3.1.1-1
	440	630	6300	6300				
UKC1-800	220	800	8000	8000	600	100	20	AC3.1.1-1
	440	800	8000	8000				

电气寿命的测试周期(AC3类)

Test period of electric life(AC3 type)

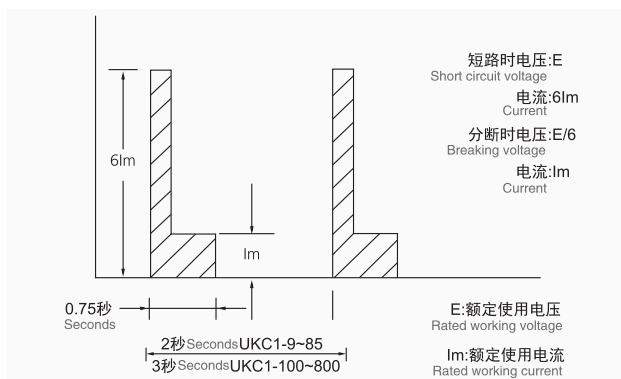

电气寿命的测试周期(AC4类)

Test period of electric life(AC4 type)

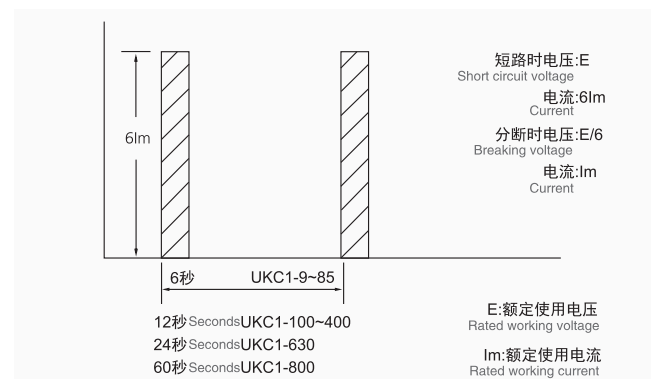

Technical Specifications

技术参数

3极接触器 Three poles contactor

型号 Model	电缆选择 Selection of cable			螺丝尺寸 Screw size		扭矩 Tightening torque(Nm)	
	AWG/MCM	截面积 Sectionl area(mm ²)		接触器端子 Contactor terminal	线圈端子 Coil terminal	主回路 Major circuit	辅助触头 Aux.contacts
		最小 Min	最大Max				
UKC1-9	10AWG	1.5	4	M4	M3.5	2.3	2.3
UKC1-12	10AWG	1.5	4	M4	M3.5	2.3	2.3
UKC1-18	8AWG	1.5	6	M4	M3.5	4	2.3
UKC1-22	8AWG	2.5	10	M4	M3.5	4	2.3
UKC1-32	6AWG	4	16	M5	M3.5	4	2.3
UKC1-40	6AWG	4	16	M5	M3.5	4	2.3
UKC1-50	4AWG	6	25	M6	M3.5	5	2.3
UKC1-65	2AWG	10	35	M8	M3.5	5	2.3
UKC1-75	2AWG	10	35	M8	M3.5	5	2.3
UKC1-85	0AWG	10	50	M8	M4	5	2.3
UKC1-100	00AWG	25	70	M8	M4	9	2.3
UKC1-125	00AWG	25	70	M8	M4	9	2.3
UKC1-150	0000AWG	35	95	M8	M4	9	2.3
UKC1-180	250AWG	50	120	M10	M4	15	2.3
UKC1-220	300AWG	70	150	M10	M4	15	2.3
UKC1-330	500AWG	90	240	M12	M4	23	2.3
UKC1-400	N ^o 2 30 × 5	150		M16	M4	23	2.3
UKC1-500	N ^o 2 40 × 5	200		M16	M4	45	2.3
UKC1-630	N ^o 2 50 × 5	240		M16	M4	57	2.3
UKC1-800	N ^o 2 60 × 5	240		M16	M4	57	2.3

4极接触器 Four poles contactor

型号 Model	电缆选择 Selection of cable		螺丝尺寸 Screw size		扭矩 Tightening torque(Nm)	
	AWG/MCM	截面积(mm ²) Sectionl area	接触器端子 Contactor terminal	线圈端子 Coil terminal	主回路 Major circuit	辅助触头 Aux.contacts
UKC1-9/4	10AWG	4	M4	M3.5	2.3	2.3
UKC1-12/4	10AWG	4	M4	M3.5	2.3	2.3
UKC1-18/4	8AWG	6	M4	M3.5	4	2.3
UKC1-22/4	8AWG	10	M4	M3.5	4	2.3
UKC1-32/4	6AWG	16	M5	M3.5	4	2.3
UKC1-40/4	6AWG	16	M5	M3.5	4	2.3
UKC1-50/4	4AWG	25	M6	M3.5	5	2.3
UKC1-65/4	2AWG	35	M8	M3.5	5	2.3
UKC1-75/4	2AWG	35	M8	M3.5	5	2.3
UKC1-85/4	0AWG	50	M8	M4	5	2.3
UKC1-100/4	00AWG	70	M8	M4	9	2.3
UKC1-125/4	00AWG	70	M8	M4	9	2.3
UKC1-150/4	0000AWG	95	M8	M4	9	2.3
UKC1-180/4	250AWG	120	M10	M4	15	2.3
UKC1-220/4	300AWG	150	M10	M4	15	2.3
UKC1-330/4	500AWG	240	M12	M4	23	2.3
UKC1-400/4	N ^o 2 30 × 5	150	M16	M4	23	2.3
UKC1-500/4	N ^o 2 40 × 5	200	M16	M4	45	2.3
UKC1-630/4	N ^o 2 50 × 5	240	M16	M4	57	2.3
UKC1-800/4	N ^o 2 60 × 5	240	M16	M4	57	2.3

注: AWG/MCM 为UL认证标准, 仅供参考

Note:AWG/MCM is a UL standard, and only for reference

Technical Specifications

技术参数

端子尺寸 Terminal size

型号 Model	端子尺寸 Terminal size				型号 Model	端子尺寸 Terminal size				
	主回路 Major loop		辅助回路 Aux.loop			主回路 Major loop		辅助回路 Aux.loop		
	端子螺丝 Terminal screw	端子尺寸 A×B×C(mm)	端子螺丝 Terminal screw	端子尺寸 A×B×C(mm)		端子螺丝 Terminal screw	端子尺寸 A×B×C(mm)	端子螺丝 Terminal screw	端子尺寸 A×B×C(mm)	
UKC1-9	M4	9.5×5×4.9	M3.5	8×5×4.9	UKH(K)-22	M4	10×6.5×5	M3.5	7.8×4.3×7.3	
UKC1-12	M4	9.5×5×4.9	M3.5	8×5×4.9		UKH(K)-40	M5	12.4×6.2×6.3	M3.5	7.8×4.3×7.3
UKC1-18	M4	9.5×5×4.9	M3.5	8×5×4.9			UKH(K)-85	M6	19×8.5×9	M3.5
UKC1-22	M4	9.5×5×4.9	M3.5	8×5×4.9	M8			19×8.5×9	M3.5	7.8×4.3×7.3
UKC1-32	M5	12.4×6.5×6	M3.5	8×5×4.9	UKH(K)-100	M8	15×9.5×9	M4	8.2×4.1×5.2	
UKC1-40	M5	12.4×6.5×6	M3.5	8×5×4.9		UKH(K)-150	M8	20×10×10	M4	8.2×4.1×5.2
UKC1-50	M6	17.5×7×8.7	M3.5	8×5×4.9	UKH(K)-220		M10	25×12.5×13.5	M3.5	7.7×5×4.5
UKC1-65	M8	17.5×7×8.7	M3.5	8×5×4.9						
UKC1-75	M8	17.5×7×8.7	M3.5	8×5×4.9						
UKC1-85	M8	17.5×7×8.7	M3.5	8×5×4.9						
UKC1-100	M8	15×8.5×9.5	M4	10.8×4.1×4.1						
UKC1-125	M8	15×8.5×9.5	M4	10.8×4.1×4.1						
UKC1-150	M8	20.5×10×9	M4	10.8×4.1×4.1						
UKC1-180	M10	25×12.5×15	M4	10.8×4.1×4.1						
UKC1-220	M10	25×12.5×15	M4	10.8×4.1×4.1						

安装和使用环境 Installation and using environment

安装 Mounting

1) 安装位置 Installation position

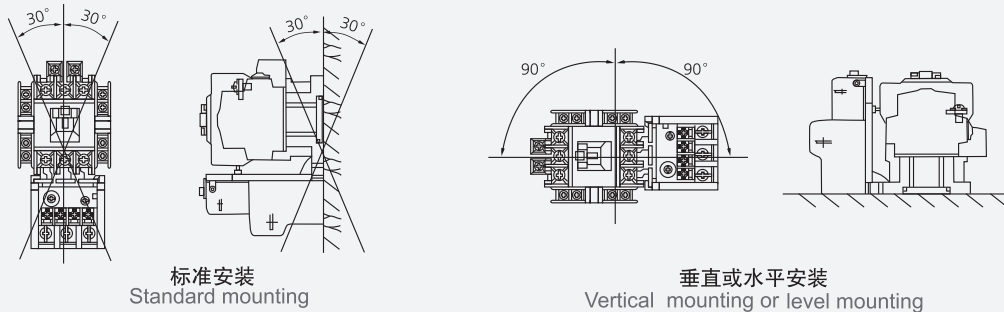

* 特殊的安装方式比正常安装要降低寿命及各种特性

* The service life and performance will be reduced if applying special installation mode rather than normal one.

2) 轨道(UKC1-9~85)

安装 Mounting

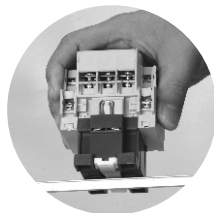

拆除 Dismantle

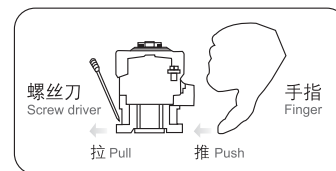

使用环境

- 1) 周围温度：基准温度20° ...(-25~40° ...)
- 2) 储存温度：-30°~65° ...
- 3) 海拔：2,000m以下
- 4) 没有结冰的环境

Environment

- 1) Ambient temperature：Base20° ...(-25~40° ...)
- 2) Storage temperature：-30°~65° ...
- 3) Altitude：2,000m and below
- 4) The environment no freezing

Mounting Dimensions & Wiring Diagram

安装尺寸及接线图

3极接触器 Three poles contactor

型号 Model	外型尺寸 External dimensions (mm)	安装尺寸 Install size
UKC1-6M UKC1-9M UKC1-12M UKC1-16M		
UKC1-9 UKC1-12 UKC1-18 UKC1-22		
UKC1-32 UKC1-40		
UKC1-50 UKC1-65 UKC1-75 UKC1-85		
	UKC1-9~22	UKC1-32~40
触点构成 Contacts form		

Mounting Dimensions & Wiring Diagram

安装尺寸及接线图

3 极接触器 Three poles contactor

型号 Model	外型尺寸 External dimensions (mm)	安装尺寸 Install size
UKC1-6M UKC1-9M UKC1-12M UKC1-16M		
UKC1-9 UKC1-12 UKC1-18 UKC1-22		
UKC1-32 UKC1-40		
UKC1-50 UKC1-65 UKC1-75 UKC1-85		
	UKC1-9~22	UKC1-32~40
触点构成 Contacts form		